

7
2.04-04-

2011 « » [1], 2.04.101-2004 « » [2].

), (« 1). « », ()
: , ,
(.1) [4].

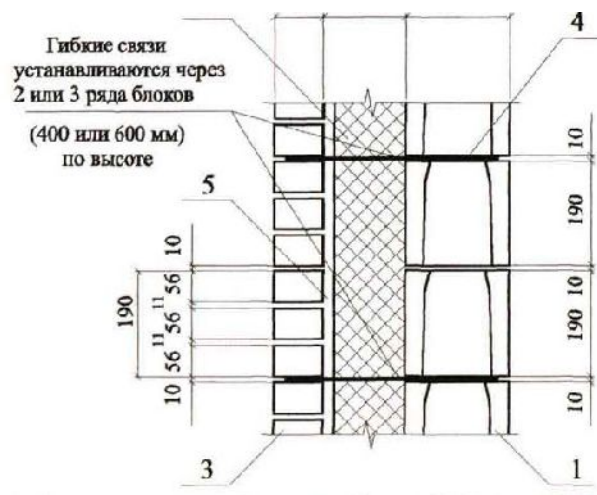

1 -

- 1.
- 2.
- 3.
- 4.
- 5.

1 -

	1 - 6/1 (• •
-	14) .	• •
	2 83/3 (• 1. 2. «ISOVER OL-P» 3. •
	3 9 - 7 9 « » .	1. • 1. • «ISOVER OL-P»
	4 9 - 101 (35)	1. • • •
	5 5 - 9 5	1. • •
« »	6 « » .	• • • •
« »	7 «Alem Plaza» .	• • • •
	8 77 (22) .	• • • • - ISOVER

2-5). 20 (1-5,

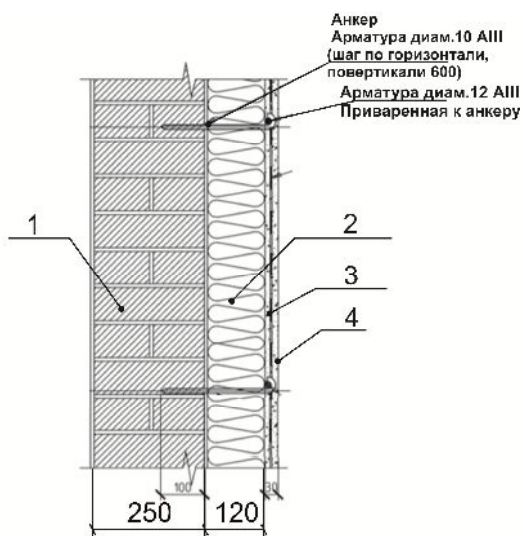

- 2 -
- 1: - 250 .
- 150 / ³ - 120 .
1. -
2. 2-20-2.0-0 5336-80*
- 3.
- 4.

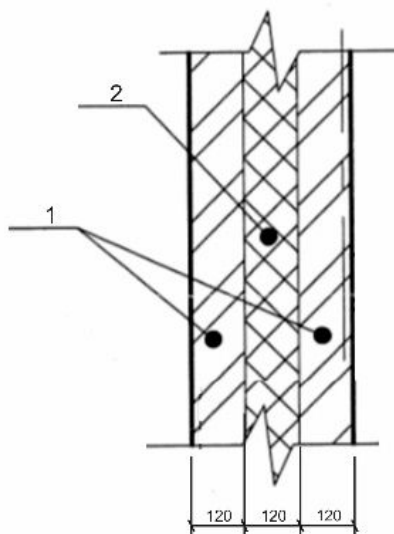

3- 2 3:

1.
100
2.

75 - 120 .

379-95

«ISOVER OL-P» Y=90 / 3 - 120 .

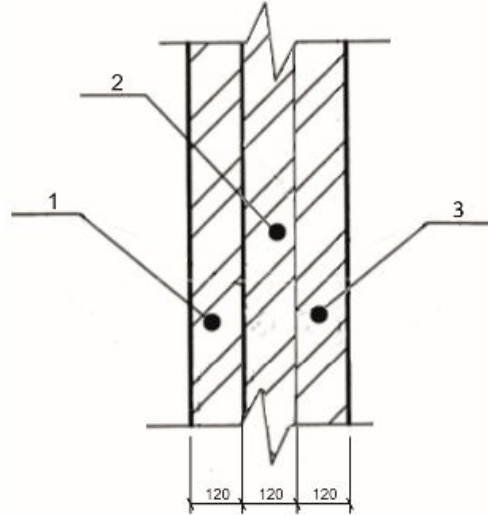

4-

379-95

4:
100

1.
75 - 120 .

2. -
3. -

- 120 .

379-95

100

75 - 120 .

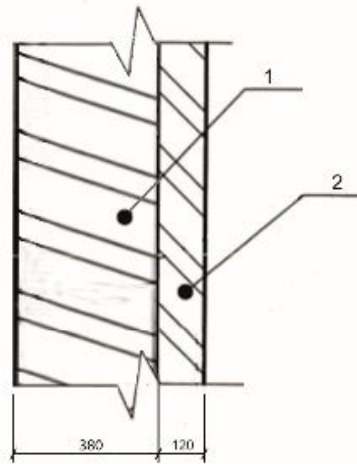

5-

5:
379-95

100

1.
75 - 120 .

2. -
100 75 - 380 .

379-95

« ».

« ».

),

20-30%

10%

30

5

600

400-600 / 3

400-

400

9-

(3-6 /),

),

«

»,

(

« »

5

« »

1. 2.04-04-2011 « ».
2. 2.04.101-2004 « ».
3. . .
4. . . . 2009. - 1. - . 4-5.

05.23.05.- , 2007.- . 7.

(

« »

- 5

« »

RESUME

As a result of the surveys of multi-layered enclosing walls in the practice of designing and building buildings in Uralsk, the most frequently used structural solutions of multilayered heat-efficient external walls were identified. These are multi-layer walls based on piece wall materials (solid brick, silicate brick), walls according to the «Ventilation facade» system, walls based on cellular concrete blocks. Of these, the most effective structural solutions of enclosing structures in the climate of the West Kazakhstan region are multi-layer walls based on cellular concrete blocks for the construction of buildings up to 5 floors, and the construction of multi-layer walls according to the «Ventilated facade» system for buildings of any number of storeys.